

# 彈弓頂針 SLING EJECTOR PIN

塑膠模用  
Plastic mold accessories

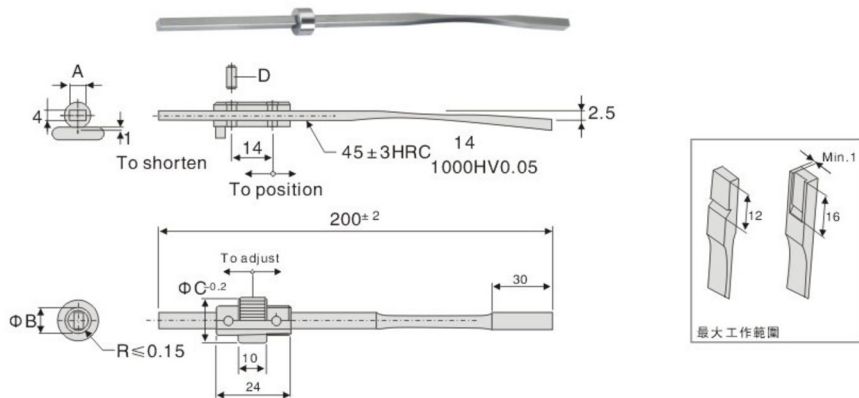

由于接觸面與頂出板平行，因而從底部釋放彈性的最小區域的厚度僅為4mm，另此產品的一個新的特點是：先頂出然後從底部釋放彈性。  
Because the contact surface is parallel with ejector plate, the thickness of release elasticity form bottom's smallest area is just 4mm, and a new characteristic of this product: first eject then release elasticity from the bottom.

Material M 材質	Hardness 硬度
1.2101	HRC58° ± 2°

Type	尺寸/dimension				
	A	B	C	D	H
JHN03-1	6	M10x0.75	16	3x8	7
JHN03-2	8	M12x0.75	18	4x10	9
JHN03-3	10	M14x0.75	20	4x12	11
JHN03-4	12	M16x0.75	22	4x14	13

## 使用例 Example

